

1964 JEFFERIES CONSTRUCTION PLANS

Data Collection and Restoration

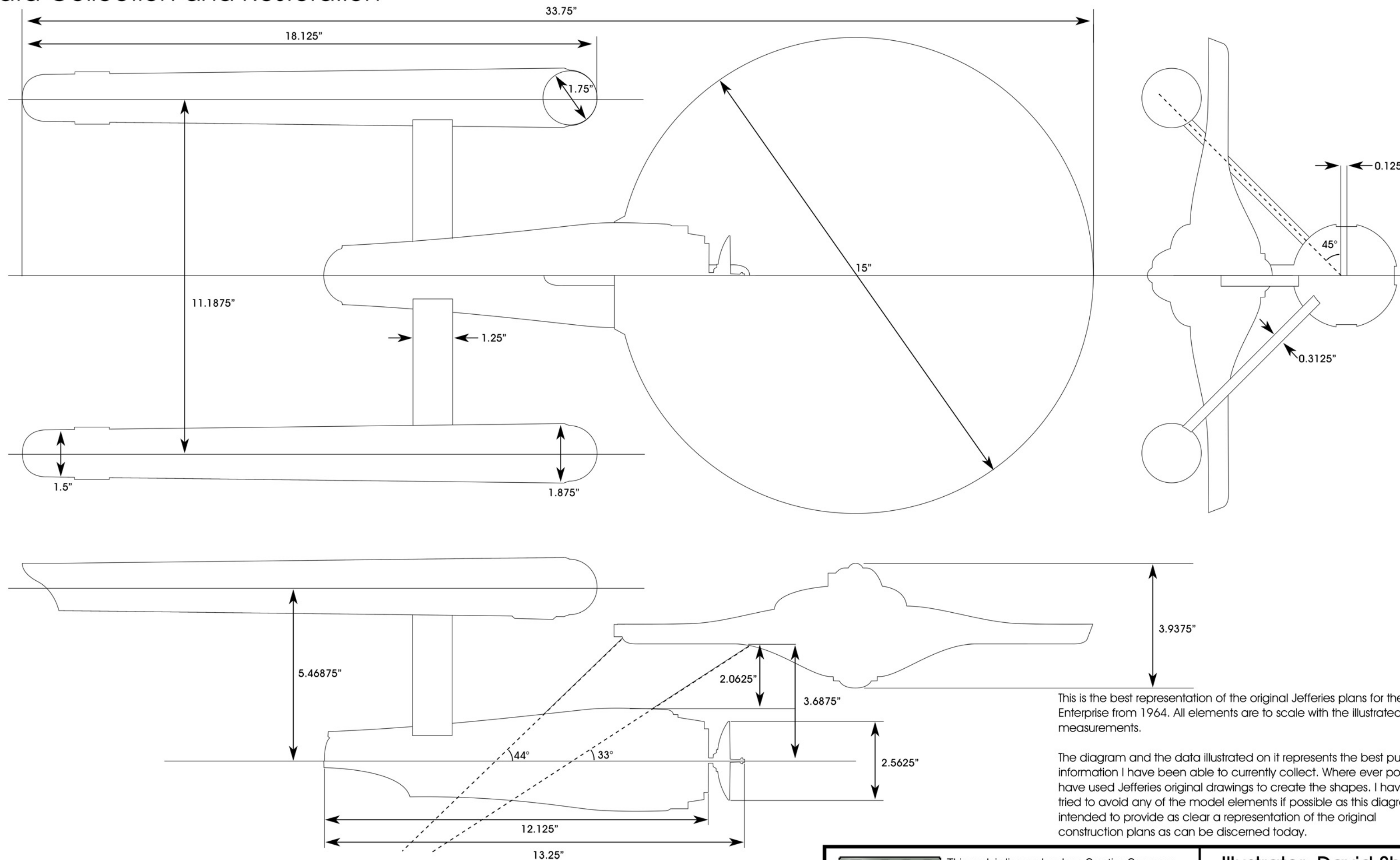

This is the best representation of the original Jefferies plans for the Enterprise from 1964. All elements are to scale with the illustrated measurements.

The diagram and the data illustrated on it represents the best public information I have been able to currently collect. Where ever possible I have used Jefferies original drawings to create the shapes. I have also tried to avoid any of the model elements if possible as this diagram is intended to provide as clear a representation of the original construction plans as can be discerned today.



This work is licensed under a Creative Commons Attribution-NonCommercial-Share Alike 3.0 United States License

Illustrator: David Shaw
Date: October 2007

1964 JEFFERIES CONSTRUCTION PLANS

Data Collection and Restoration

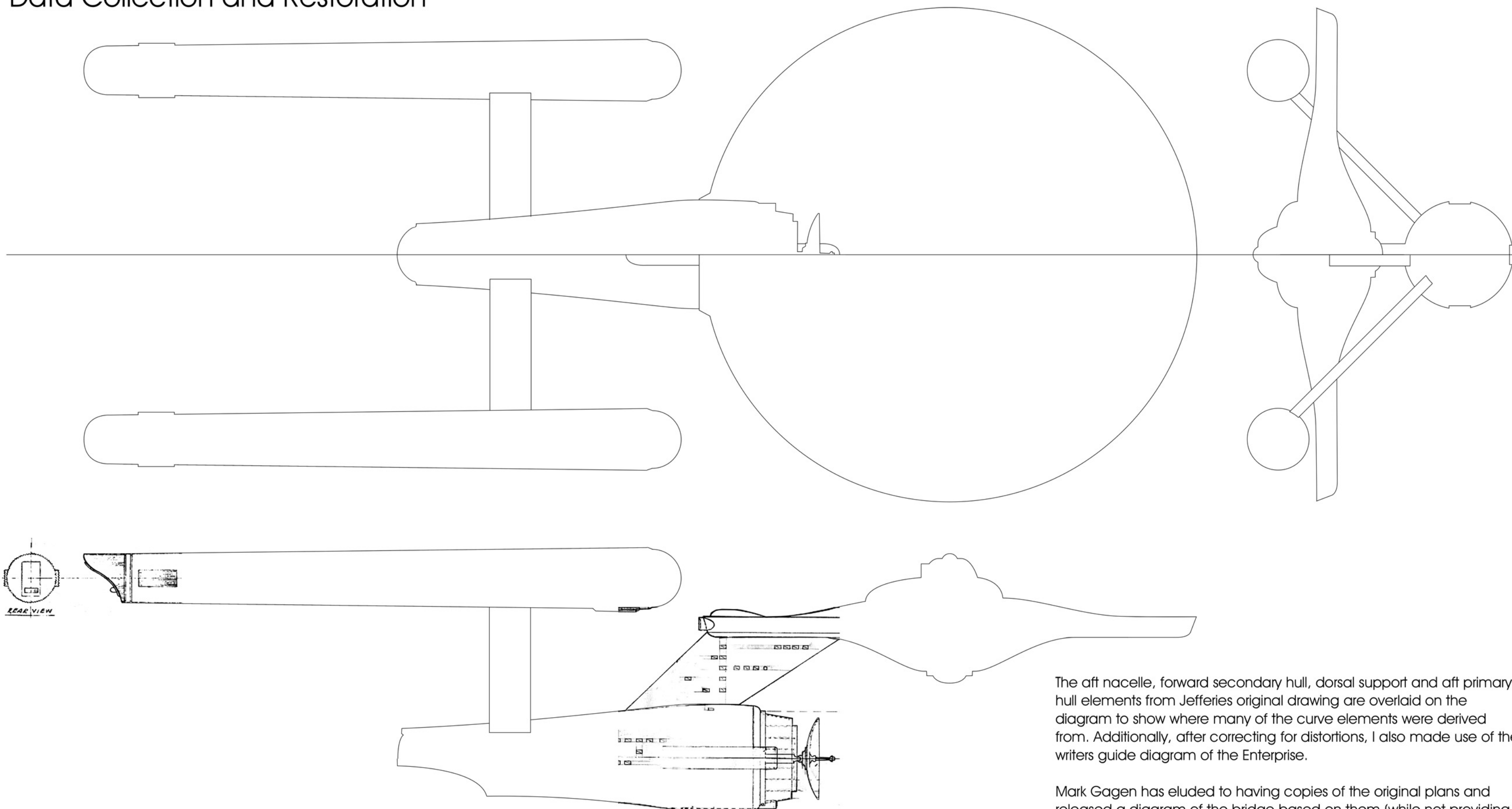

The aft nacelle, forward secondary hull, dorsal support and aft primary hull elements from Jefferies original drawing are overlaid on the diagram to show where many of the curve elements were derived from. Additionally, after correcting for distortions, I also made use of the writers guide diagram of the Enterprise.

Mark Gagen has eluded to having copies of the original plans and released a diagram of the bridge based on them (while not providing any actual images of the original drawing itself). As I have no reason to believe his diagram is flawed, I have based the size and shape of the bridge on this set of diagrams on what he provided.

1964 JEFFERIES CONSTRUCTION PLANS

Data Collection and Restoration

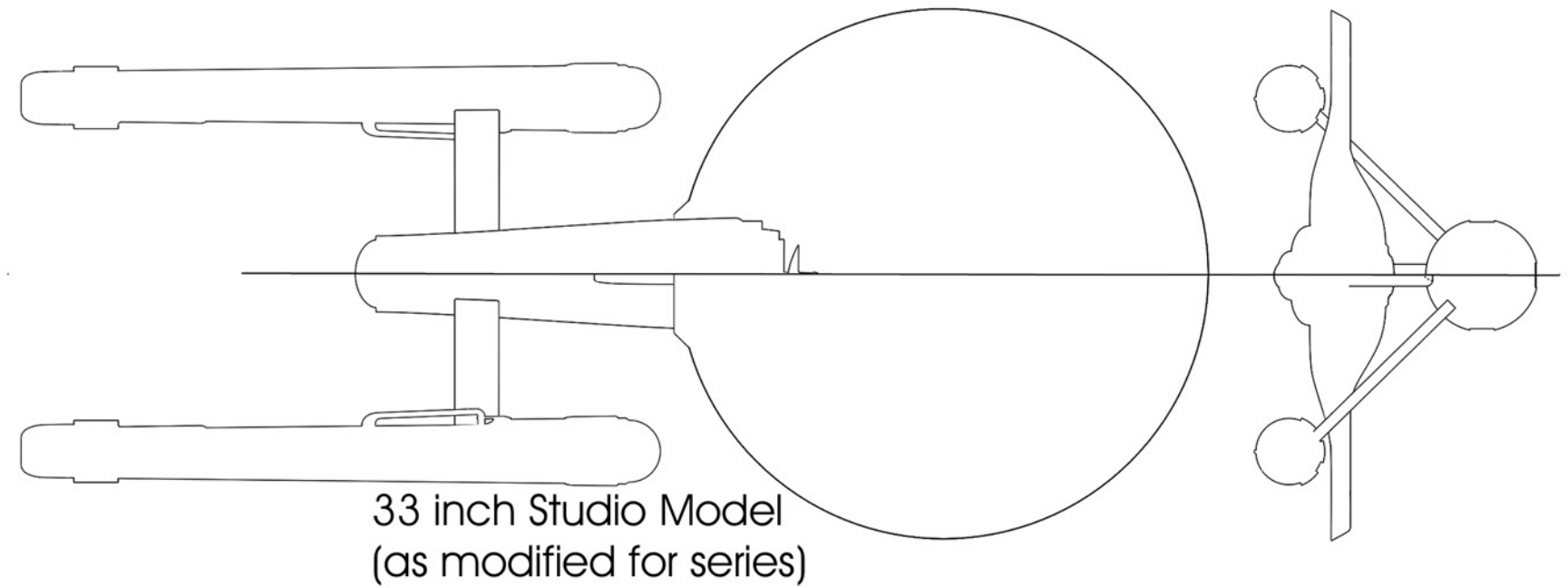
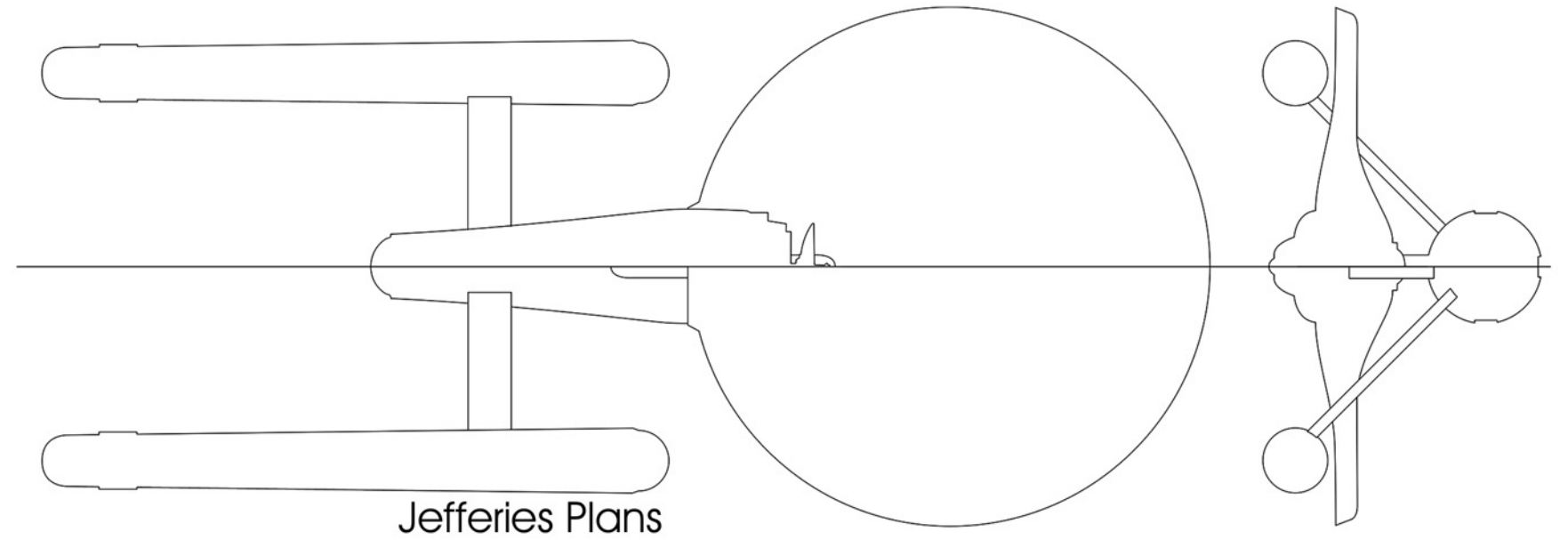
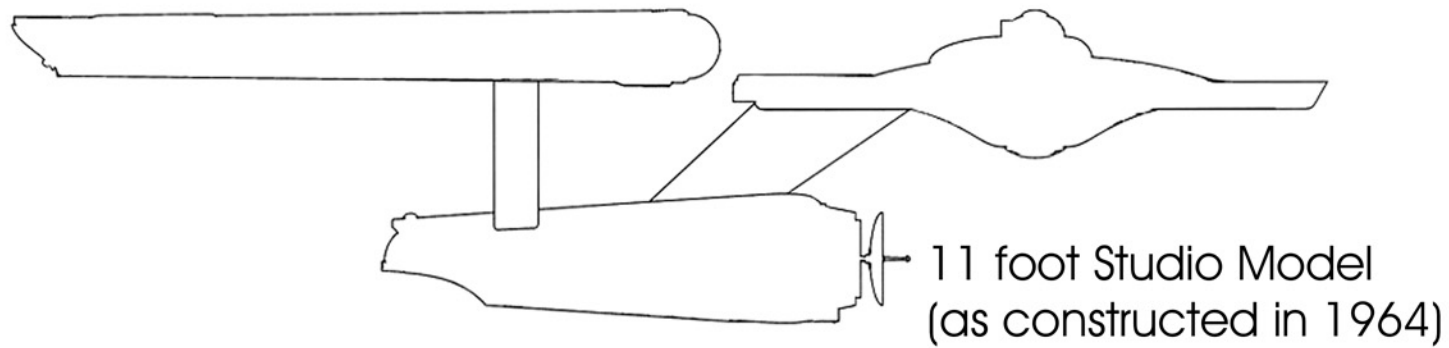
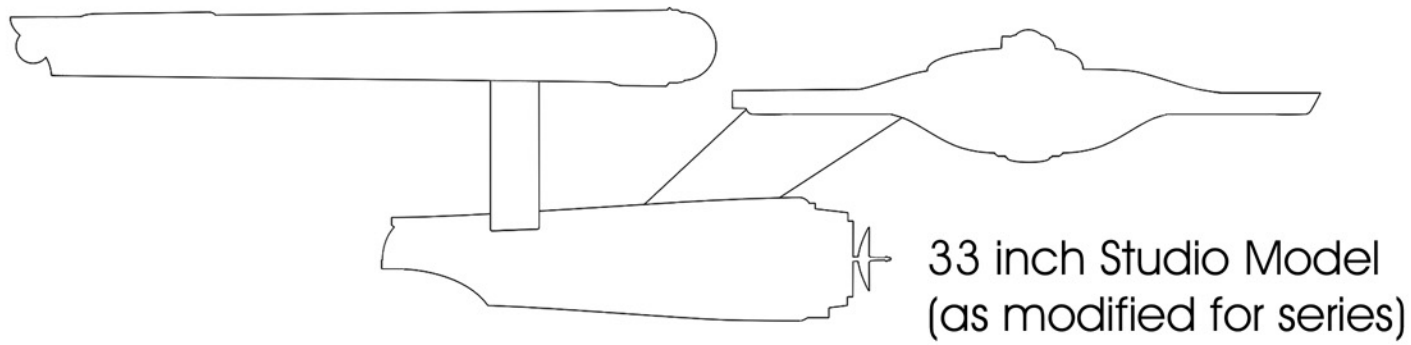
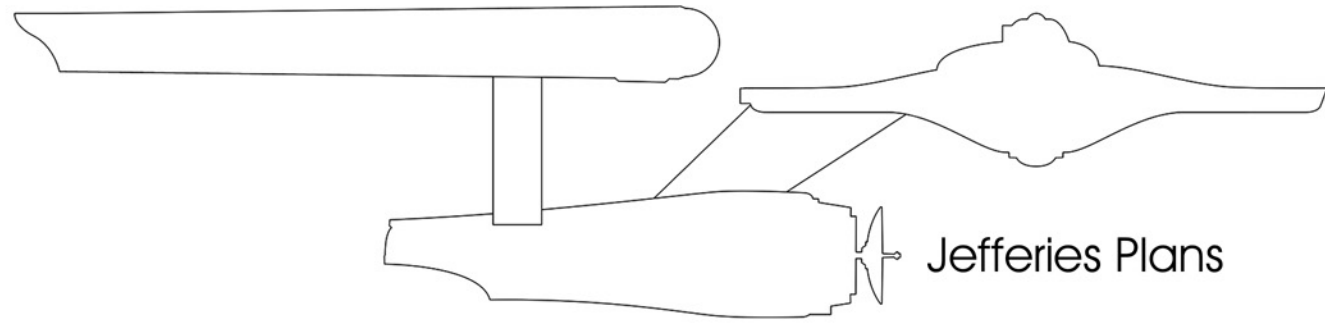

This work is licensed under a Creative Commons Attribution-NonCommercial-Share Alike 3.0 United States License

Illustrator: David Shaw
Date: October 2007